

**DISTINTA DELLE PARTI COSTITUENTI LE POMPE CENTRIFUGHE AUTOADESCANTI SERIE " J "**  
**SPARE PARTS LIST FOR "J" SERIES SELF-PRIMING PUMPS**  
**LISTE DES PIECES DE RECHANGE POUR POMPES CENTRIFUGES AUTO-AMORCANTES SERIE "J "**  
**ERSATZTEILLISTE FÜR SELBSTANSAUGENDE KREISELPUMPEN SERIE "J "**

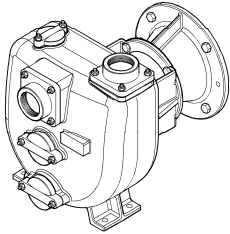

JP 3-240 G10 ETO	cod. 1004 2649
JP 3-240 F10 ETO	cod. 1004 8846
JP 3-240 Q10 ETO	cod. 1004 8847
JP 3-240 P10 ETO	cod. 1004 8056
JP 3-240 P30 ETO	cod. 1004 8055

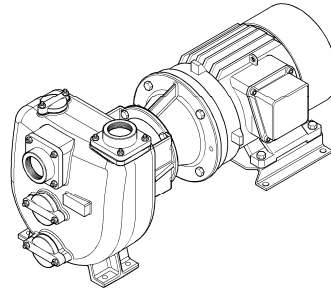

JE 3-240 G10 ETO	cod. 1004 2936
JE 3-240 F10 ETO	cod. 1004 7447
JE 3-240 Q10 ETO	cod. 1004 7449
JE 3-240 P10 ETO	cod. 1004 7450
JE 3-240 P30 ETO	cod. 1004 7451

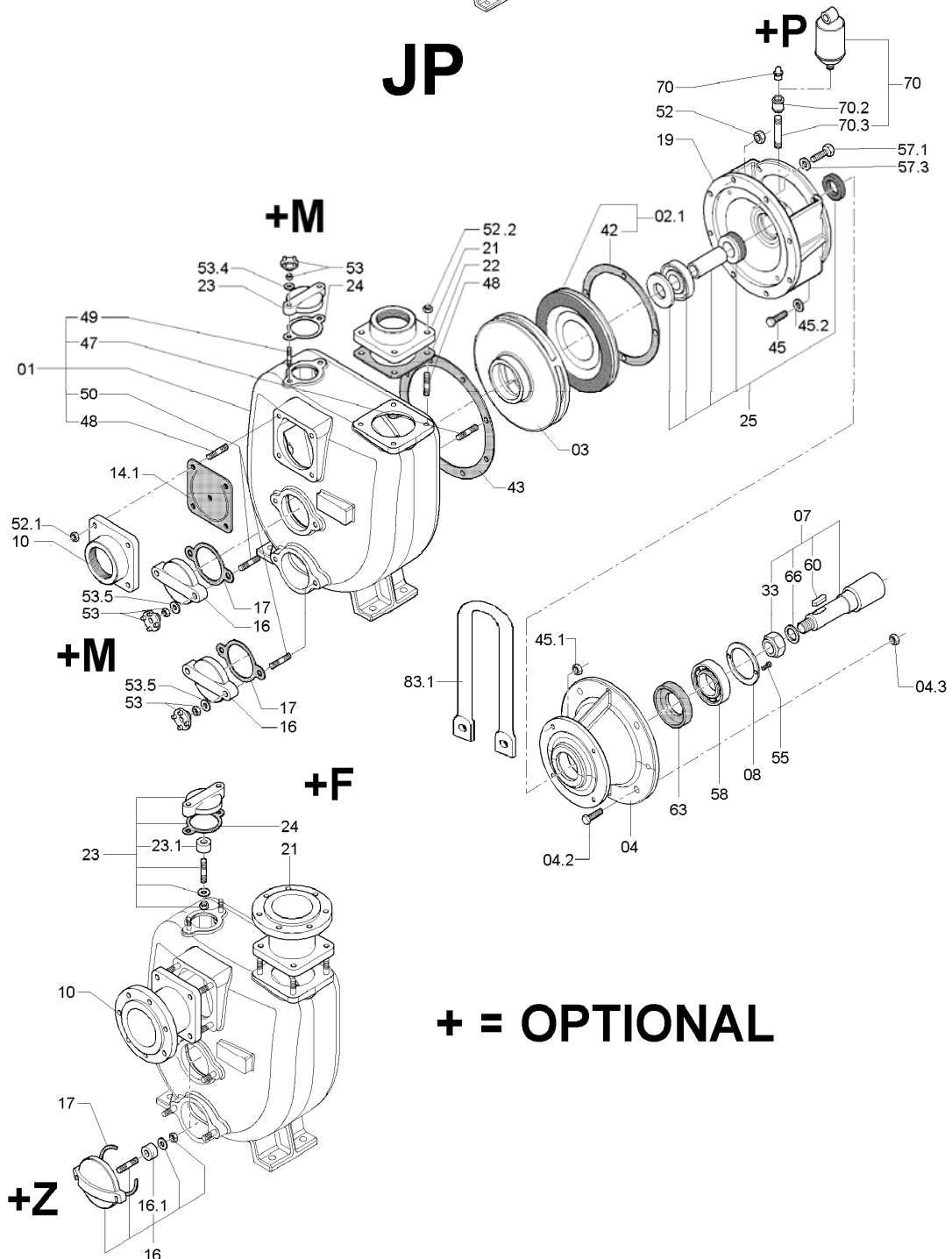

**+ = OPTIONAL**



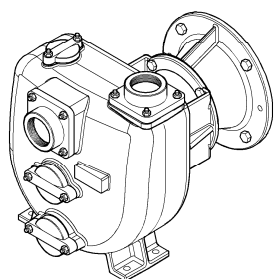

+

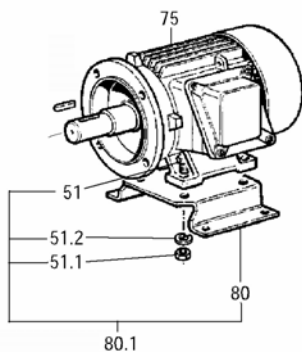

=

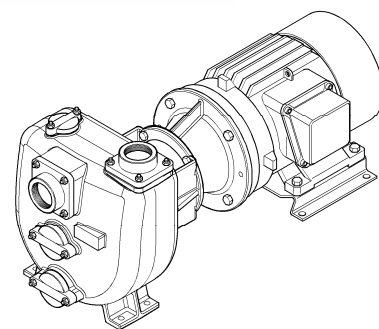

JP

+

MOTORE / MOTOR

=

JE

Rif. N° Pos. Nr.	Quant.	Denominazione	Part name	Den. Comm. Type	Mat.*	Codice Nuovo New Part. No.	JP 3-240 G10	JP 3-240 F10	JP 3-240 Q10	JP 3-240 P10	JP 3-240 P30
01	1	Corpo (1)	Casing (1)		GS	1004 7012	○			○	○
					GS	1004 8845		○	○		
02.1	1	Piatto d' usura (2)	Wear plate (2)		GN	1002 3925	○				
					G	1002 3926				○	○
					K	1002 3928		○			
					B	1002 3927			○		
03	1	Girante	Impeller		GS	1004 2642	○			○	○
					K	1004 7219		○			
					B	1004 7218			○		
04	1	Campana	Coupling flange		G	1004 0868	○	○	○	○	○
04.2	4	Vite	Screw	M 16 x 50 DIN 933	S	1000 1975	○			○	○
				M 16 x 55 DIN 933	K	1000 2071		○	○		
04.3	4	Dado	Nut	M 16 DIN 934	S	1000 1425	○			○	○
					K	1000 1442		○	○		
07	1	Albero (3)	Shaft (3)		S	1004 0866	○			○	○
					K5	1004 3197		○	○		
08	1	Copricuscinetto	Bearing cover		G	1004 0857	○	○	○	○	○
10	1	Portavalvola	Suction flange	R 3"	G	1000 6422	○	○		○	○
					OTS	1000 6399			○		
							+F	+F	+F	+F	+F
14.1	1	Valvola completa	Check valve ass.		NK	1000 9019	○				
					VK	1000 9022		○	○	○	○
16	2	Portina	Cover		G	1000 6474	○	○	○	○	○
					SZ	1000 8503	+Z	+Z	○	+Z	+Z
16.1	2	Placca zinco	Zinc anode		Z	1000 3810	+Z	+Z	○	+Z	+Z
17 (**)	2	Guarnizione	Gasket								
19	1	Portamotore	Head		G	1000 6342	○	○	○	○	○
21	1	Flangia mandata	Discharge flange	R 3"	G	1000 5090	○	○		○	○
					OTS	1000 5070			○		
							+F	+F	+F	+F	+F
22 (**)	1	Guarnizione	Gasket								
23	1	Portina	Cover		S	1000 6473	○	○	○	○	○
					SZ	1000 8502	+Z	+Z	○	+Z	+Z
23.1	1	Placca zinco	Zinc anode				+Z	+Z	○	+Z	+Z
24 (**)	1	Guarnizione	Gasket								
25	1	Anello di tenuta	Mechanical seal ass.	T 45 YYN		1002 1228	○				
				T 45 YYV		1002 1309		○	○		
				T 45 GWV		1002 3973				○	
33	1	Dado girante	Impeller nut	M 30 x 2 UNI 7474	H	1000 1466	○			○	○
					K	1000 1473		○	○		

VARISCO S.p.A.

Terza Strada, 9 - Z.I. Nord - 35129 Padova - Italy

Tel. 049 82 94 111

Fax 049 82 94 373

+39 049 82 94 111

International +39 049 80 76 762



**HEMPEL**  
AntriebsTechnik

+49 (2154) 4989-37 - pumpe@hem-net.de

**varisco**  
solid pumping solutions

Rif. N° Pos. Nr.	Quant.	Denominazione	Part name	Den. Comm. Type	Mat. *	Codice Nuovo New Part. No.	JP 3-140 G10	JP 3-140 G10	JP 3-140 G10	JP 3-140 G10	JP 3-140 G10
42 (**)	1	Guarnizione piatto	Wear plate gasket								
43 (**)	1	Guarnizione corpo	Casing gasket								
45	2	Vite	Screw	M 12 x 35 DIN 933	S	1000 1961	○			○	○
					K	1000 2067		○	○		
	2			M 12 x 45 DIN 933	S	1000 1963	○			○	○
					K	1000 2056		○	○		
45.1	4	Dado	Nut	M 12 DIN 934	S	1000 1422	○			○	○
					K	1000 1439		○	○		
45.2	4	Rondella	Washer	M 12 UNI1751/52	S	1000 1681	○			○	○
					K	1000 1685		○	○		
47 (*)	8	Prigioniero	Stud	M 12 x 30 DIN 938	S		○			○	○
					K			○	○		
48 (*)	8	Prigioniero	Stud	M 10 x 25 DIN 938	S		○			○	○
					K			○	○		
49 (*)	2	Prigioniero	Stud	M 10 x 30 DIN 938	S		○			○	○
					K			○	○		
50	4	Prigioniero	Stud	M 10 x 30 DIN 938	S		○			○	○
					K			○	○		
51	4	Vite	Screw	M 12 x 40 DIN 933	S	1000 1962	○	○	○	○	○
51.1	4	Dado	Nut	M 12 DIN 934	S	1000 1422	○	○	○	○	○
51.2	4	Rondella	Washer	M 12 DIN 125 A	S	1000 1699	○	○	○	○	○
52 (*)	8	Dado	Nut	M 12 DIN 934	S		○			○	○
					K			○	○		
52.1(*)	4	Dado	Nut	M 10 DIN 934	S		○			○	○
					K			○	○		
52.2(*)	4	Dado	Nut	M 10 DIN 934	S		○			○	○
					K			○	○		
53 (*)	4	Dado	Nut	M 10 DIN 934	S		○			○	○
					K			○	○		
53.2 (*)	2	Dado	Nut	M 10 DIN 934	S		○			○	○
					K			○	○		
53.4(*)	2	Rondella	Washer	M 10 DIN 125 A	S		○			○	○
					H			○	○		
53.5(*)	4	Rondella	Washer	M 10 DIN 125 A	S		○			○	○
					H			○	○		
55	2	Vite	Screw	M 6x25 DIN 933	S	1002 8349	○			○	○
					K	1000 2023		○	○		
57.1(*)	4	Vite	Screw	M 12 x 25 DIN 933	S		○			○	○
					H			○	○		
57.3(*)	4	Rondella	Washer	M 12 UNI1751/52 A	S		○			○	○
					H			○	○		
58	1	Cuscinetto	Ball bearing	3308 - 2RS		1004 0861	○	○	○	○	○
60	1	Linguetta	Key	10 x 8 x 40 DIN 6885A	K	1000 1626	○	○	○	○	○
63	1	Ghiera	Sleeve	35 x 50 x 10	S	1002 1222	○	○	○	○	○
66	1	Rondella	Washer	M 30 DIN 125 A	H	1000 1716	○	○	○	○	○
70	1	Ingrassatore	Grease nipple	R 1/4"		1000 1662	○	○	○	○	○
						1000 8316	+P	+P	+P	+P	+P
70.2	1	Manicotto	Union	R 1/4" M/F	S		+P	+P	+P	+P	+P
70.3	1	Prolunga	Grease tube	1/4"	S		+P	+P	+P	+P	+P
75	1	Motore V=400-690 (3ph)	A.C. motor V=400-690 (3ph)	18,5 Kw 2p B35 IP55		1004 2935	○	○	○	○	○
80	1	Piede motore	Motor base		S	1004 3158	○	○	○	○	○
80.1	1	Kit piede motore	Electric motor foot		S	1004 3178	○	○	○	○	○

VARISCO S.p.A.

Terza Strada, 9 - Z.I. Nord - 35129 Padova - Italy

Tel. 049 82 94 111

Fax 049 82 94 373

International +39 049 80 76 762



**HEMPEL**  
AntriebsTechnik

+49 (2154) 4989-37 - pumpe@hem-net.de

**varisco**  
solid pumping solutions

Rif. N° Pos. Nr.	Quant.	Denominazione	Part name	Den. Comm. Type	Mat. *	Codice Nuovo New Part. No.	JP 3-140 G10	JP 3-140 G10	JP 3-140 G10	JP 3-140 G10	JP 3-140 G10
83.1	1	Gancio di sollevam.	Lifting hook		S	100 43806	○	○	○	○	○
( * )		Serie viterie	Set of screw			1004 2644	○			○	○
						1004 7767			○		
						1004 7771		○			
( ** )		Serie guarnizioni	Set of gaskets			1004 2645	○			○	○
						1004 7768			○		
						1004 7772		○			
+ F ***		Kit flange	Kit flange	DN 80 PN 16	G	1004 2810	○			○	○
				DN 80 PN 16	B	1004 2788			○		
				DN 80 PN 16	K	1004 2791		○			
				3" ASA150	G	1004 2819	○			○	○
				3" ASA150	B	1004 2823			○		
				3" ASA150	K	1004 2827		○			
+ P ***		Kit ingrassatore	Compl. Grease kit			1000 8316	○	○	○	○	○
+ Z ***		Kit portine	Set of couver		GZ	1004 7393	○		○	○	○
+ M ***		Kit manigliette	Set of wrench		OTS	1004 2794	○	○	○	○	○
***		Optional									

Note:	Notes:
1) Completo di prigionieri (47, 48, 49, 50).	1) Complete with studs (47, 48, 49,50).
2) Completo di guarnizione (42).	2) Complete with gasket (42).
3) Completo di dado, rondella e linguette (33, 60, 61, 66)	3) Complete with nut, washer and keys (33, 60, 61, 66)
* Materiali di costruzione	* Construction materials
E3 = Centellen VS 3820	E3 = Centellen VS 3820
G = Ghisa	G = Cast iron
GS = Ghisa sferoidale	GS = Ductile cast iron
H = Acciaio inox AISI 304	H = AISI 304 stainless steel
K = Acciaio inox AISI 316	K = AISI 316 stainless steel
K5 = Acciaio inox SAF2205	K5 = SAF2205 stainless steel
N = Nitrile	N = Nitrile rubber
OTS = Ottone	OTS = Brass
S = Acciaio	S = Steel
S3 = Acciaio 38NiCrMo4	S3 = Steel 38NiCrMo4
V = Viton	V = Viton
Z = Zinco	Z = Zinc
Ordinare il materiale indicando sempre la quantità, la denominazione, il codice del pezzo, il tipo e il numero della pompa.	When ordering spares always indicate: quantity, part name and part number, type and serial number of pump.

