

DISTINTA DELLE PARTI COSTITUENTI LE POMPE CENTRIFUGHE AUTOADESCANTI SERIE " J "

SPARE PARTS LIST FOR " J " SERIES SELF-PRIMING PUMPS

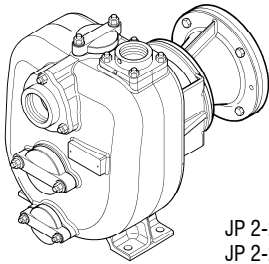

JP 2-215 G10 Code 1004 5699
 JP 2-215 F10 Code 1004 9663
 JP 2-215 P10 Code 1004 9664
 JP 2-215 Q10 Code 1004 9661

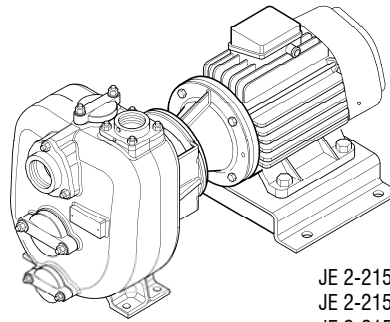

JE 2-215 G10 ET20 Code 1004 5708
 JE 2-215 F10 ET20 Code 1004 9665
 JE 2-215 P10 ET20 Code 1004 9666
 JE 2-215 Q10 ET20 Code 1004 9662

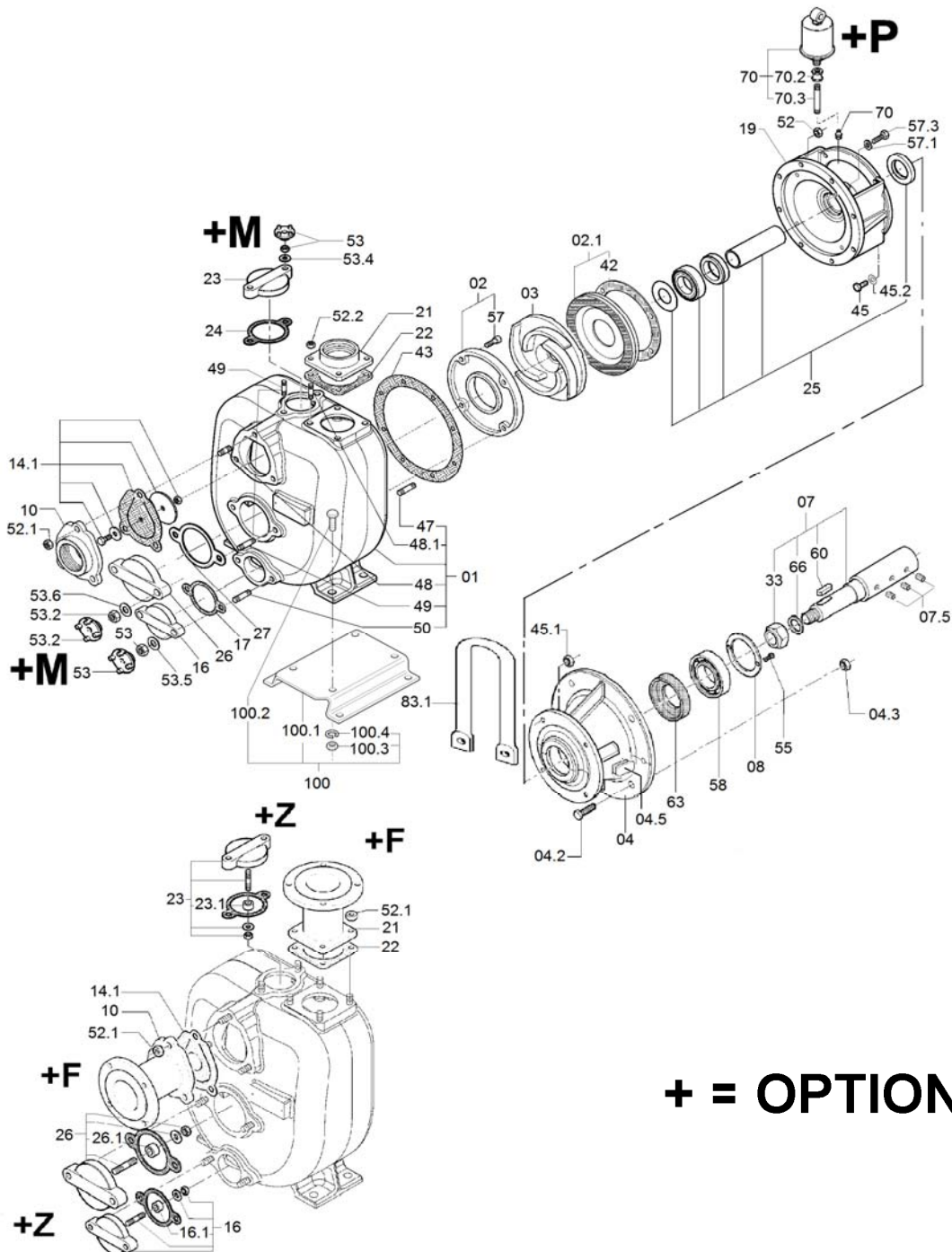

+ = OPTIONAL



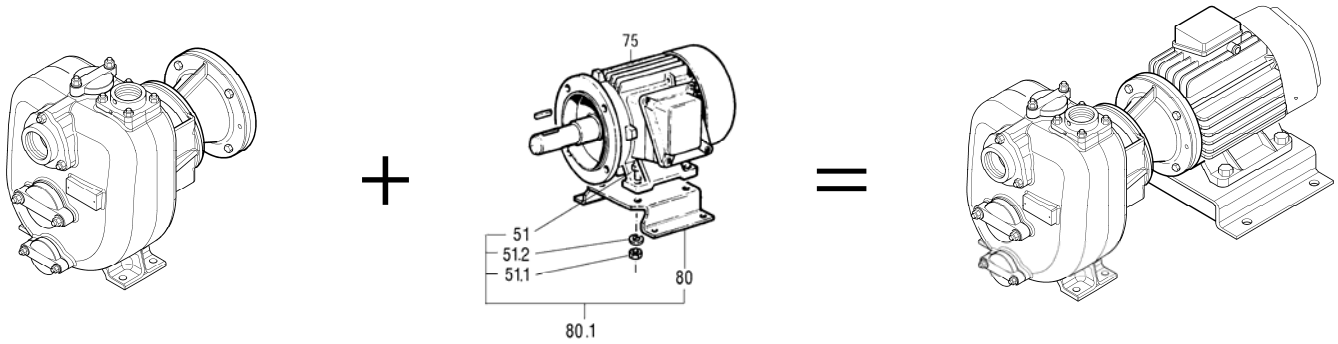

JP + MOTORE / MOTOR = JE

Rif. N° Pos. Nr.	Quant.	Denominazione	Part name	Den. Comm. Type	Mat. *	Codice Nuovo New Part. No.	JP 2-215 G10 ETO	JP 2-215 F10 ETO	JP 2-215 P10 ETO	JP 2-215 Q10 ETO
01	1	Corpo (1)	Casing (1)		GS	1004 7668	○		○	
					GS	1005 3490		○		○
02	1	Piatto d' usura (2)	Wear plate (2)		GN	1004 7670	○			
					G	1005 3493			○	
					B	1005 0096				○
					K	1005 3491		○		
02.1	1	Piatto d' usura (3)	Wear plate (3)		GN	1004 7671	○			
					G	1005 3727			○	
					B	10050095				○
					K	1005 3492		○		
03	1	Girante	Impeller		GS	1004 4620	○		○	
					B	1004 9062				○
					K	1004 9065		○		
04	1	Campana	Coupling flange		G	1004 0868	○	○	○	○
04.2	4	Vite	Screw	M 16 x 50 DIN 933	S	1000 1975	○		○	
					K	1000 2071		○		○
04.3	4	Dado	Nut	M 16 DIN 934	S	1000 1425	○		○	
					K	1000 1442		○		○
04.5	1	Tappo	Plug			1004 8471	○	○	○	○
07	1	Albero (4)	Shaft (4)		S	1004 5697	○		○	
					K	1004 9659		○		○
07.5	3	Vite	Screw	M 8x10 DIN 916	S	1004 8377	○	○	○	○
08	1	Copricuscinetto	Bearing cover		G	1004 0857	○	○	○	○
10	1	Portavalvola	Suction flange	R 2"	G	1000 6417	○	○	○	
					OTS	1000 6396				○
							+F	+F	+F	+F
14.1	1	Valvola completa	Check valve ass.		NH	1000 9015	○	○	○	○
16	1	Portina	Cover		G	1000 6473	○	○	○	
					SZ	1000 8502		+Z		+Z
16.1	2	Placca zinco	Zinc anode		Z	1000 3810		+Z		+Z
17 (**)	1	Guarnizione	Gasket							
19	1	Portamotore	Head		G	1004 5498	○	○	○	○
21	1	Flangia mandata	Discharge flange	R 2"	G	1000 5085	○	○	○	
					OTS	1000 5068				○
							+F	+F	+F	+F
22 (**)	1	Guarnizione	Gasket							
23	1	Portina	Cover		S	1000 6474	○	○	○	
					SZ	1000 8503		+Z		+Z
23.1	2	Placca zinco	Zinc anode				+Z		+Z	○
24 (**)	1	Guarnizione	Gasket							
25	1	Anello di tenuta	Mechanical seal ass.	T 35 YYN T 35 YYV		1004 4630	○			
						1004 9159		○	○	○
26	1	Portina	Cover		G	1000 6473	○	○	○	
					SZ	1000 8502		+Z		+Z
26.1	2	Placca zinco	Zinc anode		Z	1000 3810		+Z		+Z
27 (**)	1	Guarnizione	Gasket							
33	1	Dado girante	Impeller nut	M 24 x 2 UNI 7474	H	1000 1465	○		○	
					K	1000 1472		○		○

VARISCO S.p.A.

Terza Strada, 9 - Z.I. Nord - 35129 Padova - Italy

Tel. 049 82 94 111

+39 049 82 94 111

Fax 049 82 94 373

International +39 049 80 76 762



HEMPEL
AntriebsTechnik

+49 (2154) 4989-37 - pumpe@hem-net.de



varisco
solid pumping solutions

Rif. N° Pos. Nr.	Quant.	Denominazione	Part name	Den. Comm. Type	Mat.*	Codice Nuovo New Part. No.	JP 2-215 G10 ET0	JP 2-215 F10 ET0	JP 2-215 P10 ET0	JP 2-215 Q10 ET0
42 (**)	1	Guarnizione piatto	Wear plate gasket							
43 (**)	1	Guarnizione corpo	Casing gasket							
45	4	Vite	Screw	M 12 x 35 DIN 933	S	1000 1961	○		○	
					K	1000 2067		○		○
45.1	4	Dado	Nut	M 12 DIN 934	S	1000 1422	○		○	
						1000 1439		○		○
45.2	4	Rondella	Washer	M 12 UNI1751/52	S	1000 1681	○		○	
						1000 1685		○		○
47 (*)	8	Prigioniero	Stud	M 10 x 30 DIN 938	S		○		○	
					K			○		○
48 (*)	3	Prigioniero	Stud	M 10 x 25 DIN 938	S		○		○	
					K			○		○
48.1 (*)	4	Prigioniero	Stud	M 10 x 25 DIN 938	S		○		○	
					K			○		○
49 (*)	4	Prigioniero	Stud	M 10 x 30 DIN 938	S		○		○	
					K			○		○
50	2	Prigioniero	Stud	M 10 x 30 DIN 938	S		○		○	
					K			○		○
51	4	Vite	Screw	M 12 x 45 DIN 931	S	1000 1963	○	○	○	○
51.1	4	Dado	Nut	M 12 DIN 934	S	1000 1422	○	○	○	○
51.2	4	Rondella	Washer	M 12 DIN 125A	S	1000 1699	○	○	○	○
52 (*)	8	Dado	Nut	M 12 DIN 934	S		○		○	
					K			○		○
52.1(*)	4	Dado	Nut	M 10 DIN 934	S		○		○	
					K			○		○
52.2(*)	4	Dado	Nut	M 10 DIN 934	S		○		○	
					K			○		○
53 (*)	4	Dado	Nut	M 10 DIN 934	S		○		○	
					K			○		○
		Maniglietta	Wrench	M 10	OTS		+M		+M	○
53.2 (*)	2	Dado	Nut	M 10 DIN 934	S		○		○	
					K			○		○
		Maniglietta	Wrench	M 10	OTS		+M		+M	○
53.4(*)	2	Rondella	Washer	M 10 DIN 125 A	S		○		○	
					K			○		○
53.5(*)	2	Rondella	Washer	M 10 DIN 125 A	S		○		○	
					K			○		○
55	4	Vite	Screw	M 6x25 DIN 933	S	1002 8349	○	○	○	○
57.1(*)	4	Vite	Screw	M 8 x 20 DIN 933	S		○		○	
					K			○		○
57.3(*)	4	Rondella	Washer	M 8 UNI1751/52 A	S		○		○	
					K			○		○
58	1	Cuscinetto	Ball bearing	3308 2RS		1004 0861	○	○	○	○
60	1	Linguetta	Key	8 x 7 x 30 DIN 6885A	K	1002 8331	○	○	○	○
63	1	Ghiera	Look ring	30 x 49 x 4	S	1004 5696	○	○	○	○
66	1	Rondella	Washer	M 24 DIN 125 A	H	1000 1714	○		○	
								○		○
70	1	Ingrassatore	Ingrassatore	R 1/4"		1000 1662	○	○	○	○
						1000 8316	+P	+P	+P	+P
70.2	1	Manicotto	Union	R 1/4" M/F	S		+P	+P	+P	+P
70.3	1	Prolunga	Grease tube	1/4"	S		+P	+P	+P	+P
75	1	Motore V=400-690(3ph)	A.C.motor V=400-690(3ph)	11 kW 2p B35 IP55		1004 2939	○	○	○	○
80	1	Piede motore	Motor base		S	1004 3159	○	○	○	○
80.1	1	Kit piede motore	Electric motor foot		S	1004 3182	○	○	○	○
83.1	1	Gancio di sollev.	Lifting hook		S	1004 3806	○	○	○	○

VARISCO S.p.A.

Terza Strada, 9 - Z.I. Nord - 35129 Padova - Italy

Tel. 049 82 94 111

+39 049 82 94 111

Fax 049 82 94 373

International +39 049 80 76 762



HEMPEL
AntriebsTechnik

+49 (2154) 4989-37 - pumpen@hem-net.de



varisco
solid pumping solutions

Rif. N° Pos. Nr.	Quant.	Denominazione	Part name	Den. Comm. Type	Mat. *	Codice Nuovo New Part. No.	JP 2-215 G10 E10	JP 2-215 F10 E10	JP 2-215 P10 E10	JP 2-215 Q10 E10
100	1	Kit piede pompa	Pump base kit		S	1004 5706	○	○	○	○
100.1	1	Piede pompa	Pump base	330 x 120 x 65	S	1004 5705	○	○	○	○
100.2	4	Vite	Screw	M 12 x 30 DIN 933	S	1000 1960	○	○	○	○
100.3	4	Dado	Nut	M 12 DIN934	S	1000 1422	○	○	○	○
100.4	4	Rondella	Washer	M 12 DIN 125A	S	1000 1699	○	○	○	○
(*)		Serie viterie	Set of screw			1003 9798	○		○	
						1004 9645				○
						1004 9646		○		
(**)		Serie guarnizioni	Set of gaskets		N	1003 9797	○		○	
					V	1004 9157		○		○
+F ***		Kit flange	Kit flange	DN 50 PN 16	G	1004 2783	○	○	○	
					B	1004 2786				○
				2" ASA150	G	1004 2818	○	○	○	
					B	1004 2805				○
+P ***		Kit ingrassatore	Compl. Grease kit			1000 8316	○	○	○	○
+Z ***		Kit portine	Set of couver		GZ	1001 4128	+Z		+Z	○
+M ***		Kit maniglie	Set of wrench		OTS	1004 2794	○	○	○	○
***		Optional								

Note:	Notes:
1) Completo di prigionieri (47, 48, 49, 50).	1) Complete with studs (47, 48, 49,50).
2) Completo di viti (57).	2) Complete with screws (57).
3) Completo di guarnizione (42).	3) Complete with gasket (42).
4) Completo di dado, rondella e linguette (33, 60, 61, 66)	4) Complete with nut, washer and keys (33, 60, 61, 66)
* Materiali di costruzione	* Construction materials
E3 = Centellen VS 3820	E3 = Centellen VS 3820
B = Bronzo	B = Bronze
G = Ghisa	G = Cast iron
GS = Ghisa sferoidale	GS = Ductile cast iron
H = Acciaio inox AISI 304	H = AISI 304 stainless steel
K = Acciaio inox AISI 316	K = AISI 316 stainless steel
N = Nitrile	N = Nitrile rubber
OTS = Ottone	OTS = Brass
S = Acciaio	S = Steel
Z = Zinco	Z = Zinc
Ordinare il materiale indicando sempre la quantità, la denominazione, il codice del pezzo, il tipo e il numero della pompa.	When ordering spares always indicate: quantity, part name and part number, type and serial number of pump.

